

Swirl Diffusers

- Type VDL
- adjustable, for mounting heights ≥ 3.80 m



TROX[®] TECHNİK

• TROX GmbH
• Heinrich-Trox-Platz
• D-47504 Neukirchen-Vluyn

Telephone +49/28 45/2 02-0
Telefax +49/28 45/2 02-2 65
e-mail trox@trox.de
www.troxtechnik.com

Contents · Description

Description	2
Construction · Dimensions	3
Construction · Dimensions · Materials	4
Installation	5
Nomenclature · Quick Selection · Example	6
Acoustic Data · Pressure Drop	7
Aerodynamic Data for Heating	9
Aerodynamic Data for Cooling	10
Order Details	12

Description

For spaces with varying heat loads, the supply air often has to be either cool, isothermal or warm as required.

With the VDL adjustable swirl diffusers, the blade position can be altered (horizontal, angled or vertical air discharge) to give optimum penetration into the occupied zone when cooling or heating, at the same time meeting good comfort criteria.

With high air handling capacity, the swirl diffuser is suitable for use in industrial and comfort conditioning environments.

The diffuser can be used with large floor to ceiling heights (e. g. factories, airport terminals, theatres, banking halls) also in lower ceiling applications ≥ 3.80 m (e. g. assembly rooms), particularly where the supply air temperature differential varies between -10 K and +15 K.

On the constructions with fixed air control blades, the air is discharged in a horizontal direction only.

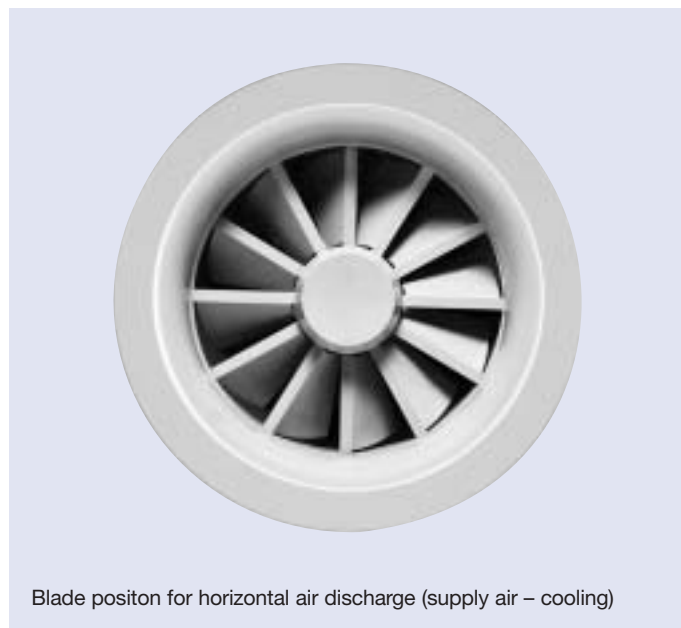

Blade position for horizontal air discharge (supply air – cooling)



Blade position for 45° discharge (supply air – isothermal)

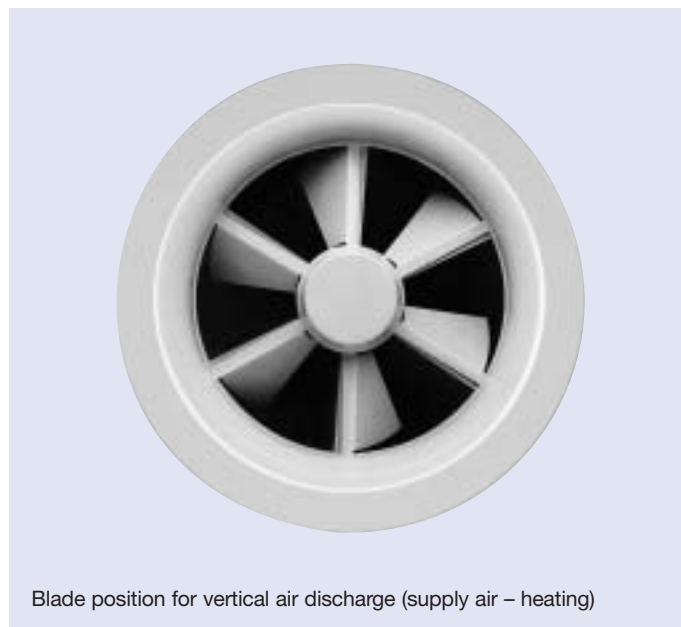

Blade position for vertical air discharge (supply air – heating)

Construction

The VDL swirl diffusers are available in four sizes. The diffuser face comprises an outer ring incorporating a discharge nozzle, air control blades (adjustable or fixed), a central cover cap and a rear mounted spigot. The blade position can be adjusted either manually by taking off the cap and loosening the winged screw or by means of an electric actuator. The outer discharge ring is supplied on request with or without a flange.

The units with a removable face have a safety cable between plenum box/casing and diffuser face. The face can easily be fitted or removed by means of 3 quick release fasteners.

The unit variants with top entry casings are connected directly to the duct. The casings are provided with a reinforcing edge. A lip seal is optional. The diffuser sizes 630 and 800 are supplied with additional opposed action swirl blades.

Dimensions in mm

Size	A	ØD1	ØD2	ØD3	H1	H2	H3	H4
315	42	313	464	381	145	92	80	215
400	45	398	567	468	157	101	89	236
630	51	628	871	700	204	117	105	367
800	55	798	1077	871	229	123	111	538

VDL-...-F

(VDL-A-F-M shown)

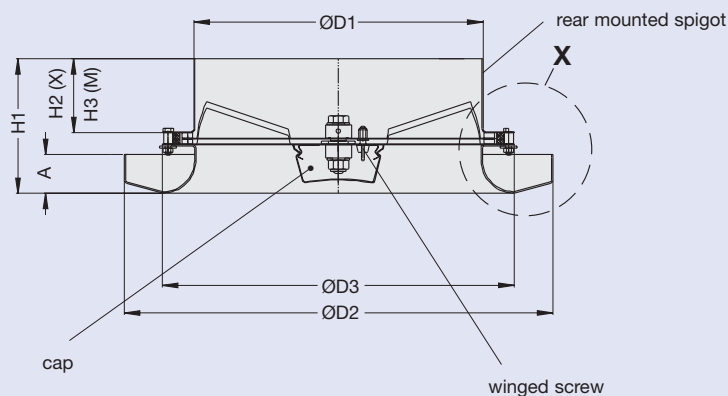

View X

Discharge ring without flange (A)

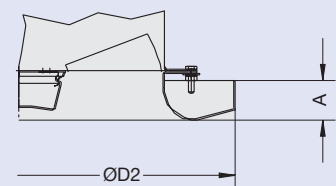

VDL-...-V

(VDL-B-V-D-E1...E3 shown)

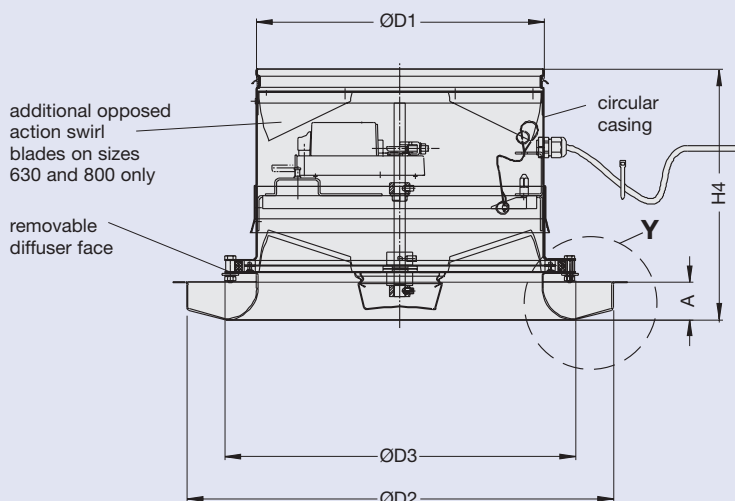

View Y

Discharge ring with flange (B)

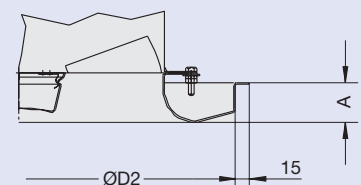

Construction · Dimensions · Materials

Construction

Type VDL-...-H swirl diffuser sizes 315 and 400 with side entry spigots are supplied with an internal fixed angled perforated plate in the plenum box. The diffuser sizes 630 and 800 are supplied with additional opposed action swirl blades.

The circular spigot is supplied with a lip seal upon request. If the diffuser is freely suspended from a ceiling, a square collar can be fitted to the diffuser face.

An optional protection grid can be supplied for use in sports halls.

Materials

The outer ring incorporating a discharge nozzle and the central cover cap are made of aluminium. The blades, casing, spigots and plenum box are made of galvanised sheet steel.

The surface of the diffuser face, collar and protection grid are powder-coated white (RAL 9010, gloss level 50 %), or in another RAL colour if requested (gloss level 70 % or RAL 9006 gloss level 30 %).

Dimensions in mm

Size	A	ØD2	ØD3	ØD4	ØD5	ØD6	H5	H6	H7	H8	□C	□K
315	42	464	381	317	248	488	474	150	282	290	630	435
400	45	567	468	402	313	591	581	168	368	351	800	500
630	51	871	700	628	398	895	812	293	468	526	1260	750
800	55	1077	871	798	498	1101	1081	458	568	741	1600	1000

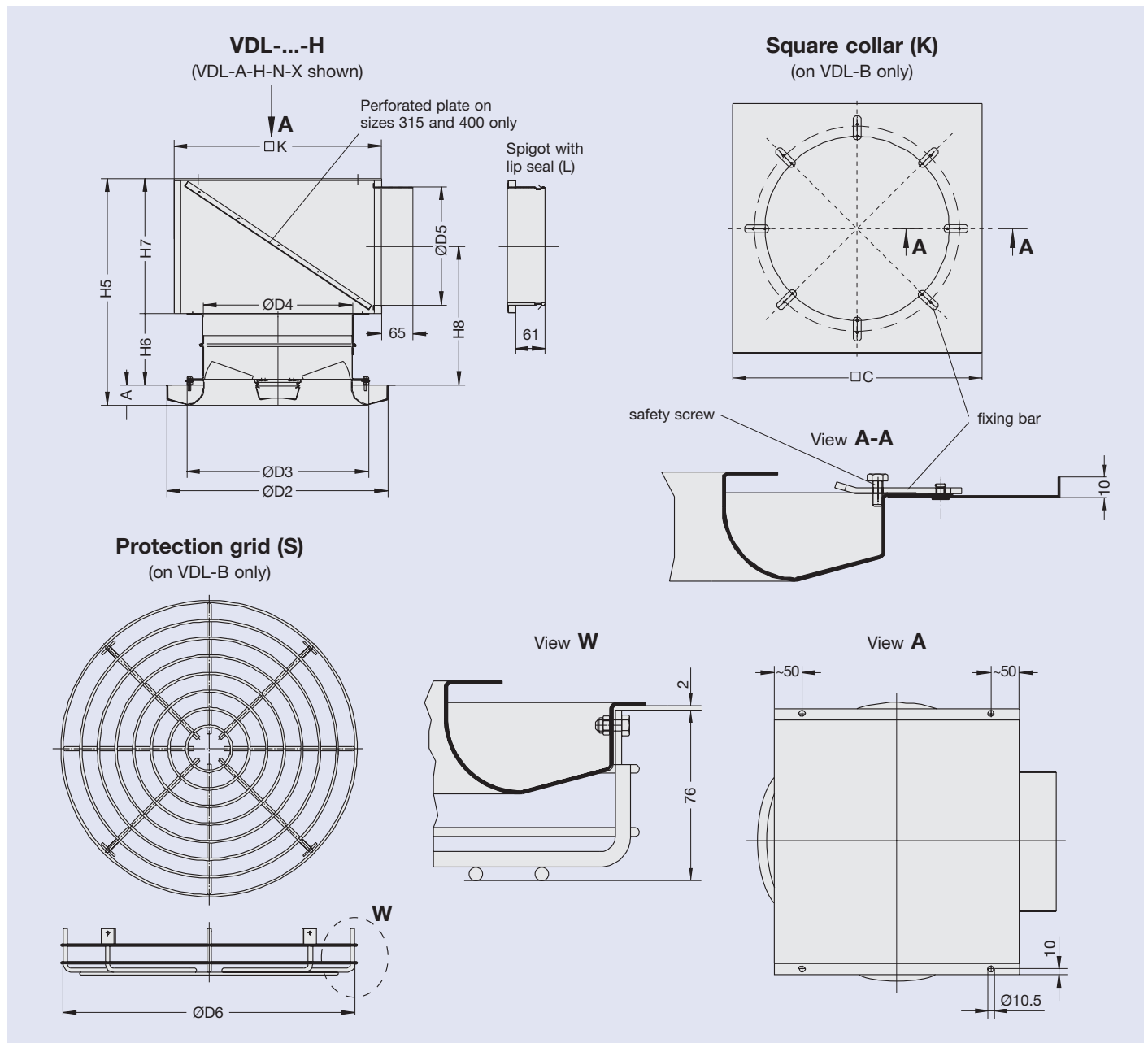

Installation

Due to their method of operation, the VDL swirl diffusers can be mounted flush in a ceiling or suspended in free space.

When fitted flush in open grid ceilings, the discharge characteristics are the same as when suspended in free space. The angle of the air discharge is continuously adjustable.

Type VDL-...-H swirl diffusers are suspended by the customer on cables or slotted strips using the drillings provided. Type VDL-...-F and VDL-...-V are mounted directly on the duct.

The installation of the diffuser face and access to or replacement of an actuator can easily be carried out by the operation of the 3 quick release fasteners (see detail Z).

Required opening sizes for flush installation in a flat ceiling				
Size	315	400	630	800
ØD7	400	500	750	950

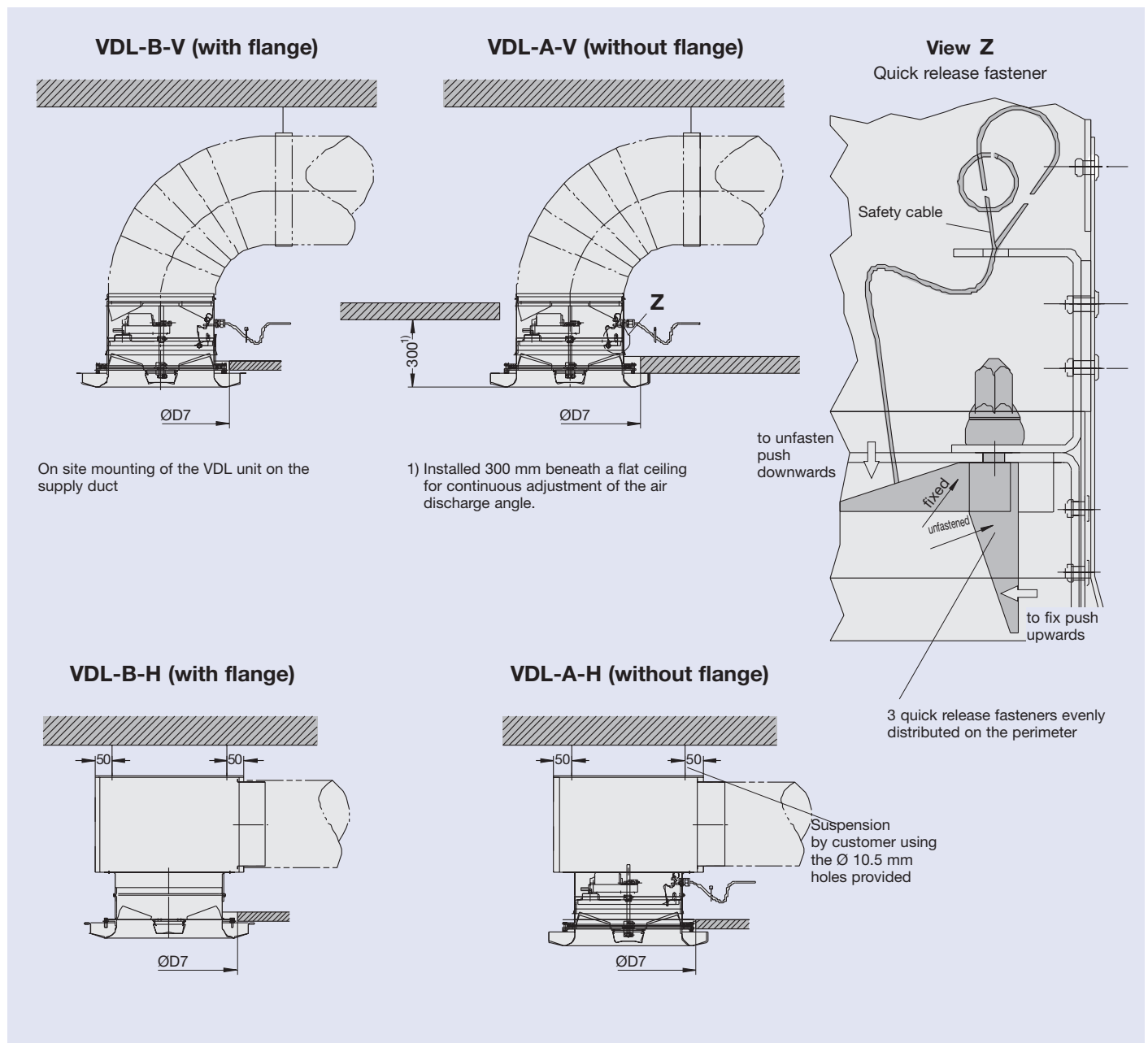

Nomenclature · Quick Selection · Example

Definitions

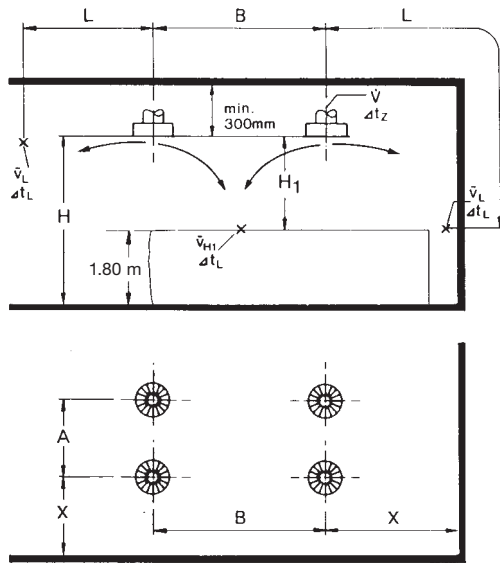

\dot{V}	in m ³ /h or l/s:	Volume flow rate per diffuser
A, B	in m:	Spacing between two diffusers
X	in m:	Distance between centre of diffuser and the wall
H ₁	in m:	Distance between diffuser face and occupied zone
\bar{v}_{H1}	in m/s:	Max. time average air velocity between two diffusers at distance H ₁ from diffuser face
L	in m:	Distance horizontal + vertical (X + H ₁) when discharging towards the wall
\bar{v}_L	in m/s:	Max. time average air velocity at the wall
H _{1max}	in m:	Maximum penetration depth of the air flow for heating
Δt_z	in K:	Temperature difference between supply air and room air
Δt_L	in K:	Difference between core and room temperature at distance L = A/2 + H ₁ or L = X + H ₁
A _{eff}	in m ² :	Effective outlet area
Δp_t	in Pa:	Total pressure drop
L _{WA}	in dB(A):	A-weighted sound power level
L _{WNC}	:	NC rating of sound power level
L _{WNR}	:	L _{WNR} = L _{WNC} + 2
L _{pA} , L _{pNC}	:	A-weighting and NC rating respectively of room sound pressure level
		L _{pA} ≈ L _{WA} - 8 dB
		L _{pNC} ≈ L _{WNC} - 8 dB

Quick selection

Size	A _{eff} m ²	\dot{V}_{min} l/s	\dot{V}_{min} m ³ /h	$\dot{V}_{max}^{1)}$ l/s	$\dot{V}_{max}^{1)}$ m ³ /h	H _{1max (+10K)} m
315	0.022	70 ²⁾	252 ²⁾	300	1080	5
400	0.031	125	450	500	1800	6
630	0.077	230 ³⁾	828 ³⁾	1020	3672	8
800	0.106	320 ⁴⁾	1152 ⁴⁾	1220	4392	9

- 1) Sound power for VDL-...-F and VDL-...-V $\hat{=} 60$ dB(A)
- 2) with fixed construction $\dot{V}_{min} = 90$ l/s = 324 m³/h
- 3) with fixed construction $\dot{V}_{min} = 250$ l/s = 900 m³/h
- 4) with fixed construction $\dot{V}_{min} = 360$ l/s = 1300 m³/h

Example

Data given:
Type VDL (top entry connection); size 800

Volume flow per diffuser $\dot{V} = 3000$ m³/h
(830 l/s)

Supply air temperature difference:
horizontal for cooling $\Delta t_z = -10$ K
vertical for heating $\Delta t_z = +10$ K
max. sound power level L_{WA} = 50 dB(A)
Spacing between diffusers A = 5.00 m
Spacing between diffusers B = 6.00 m
Distance between centre of diffuser and wall X = 2.50 m
Distance between diffuser face and occupied zone H₁ = 4.50 m

Diagram 4: Sound power level and pressure drop
L_{WA} = 49 dB(A) (L_{WNC} = 43 NC)
 $\Delta p_t = 48$ Pa

The resulting sound power level of 49 dB(A) is below the specified level of 50 dB(A). To determine the room level, the number of diffusers and the room absorption must be taken into account.

Diagram 12: Max. penetration depth for vertical discharge
 $\dot{V} = 3000$ m³/h = 830 l/s
 $\Delta t_z = +10$ K
H_{1max} = 5.5 m

Hence the warm air penetrates into the occupied zone during heating.

Diagram 16: Air velocity in occupied zone during cooling

A = 5.00 m
H₁ = 4.5 m
 $\bar{v}_{H1} < 0.2$ m/s

Diagram 20: Air velocity at the wall and temperature quotient

L = X + H₁ = 2.5 + 4.5 = 7 m
 $\bar{v}_L = 0.22$ m/s
 $\Delta t_L / \Delta t_z = 0.09$
 $\Delta t_L = -10 \times 0.09 = -0.9$ K

Acoustic Data · Pressure Drop (adjustable types)

The sound power level and pressure drop of type VDL-...-F correspond to the values of type VDL-...-V.

1 Sound power level and pressure drop
Size 315

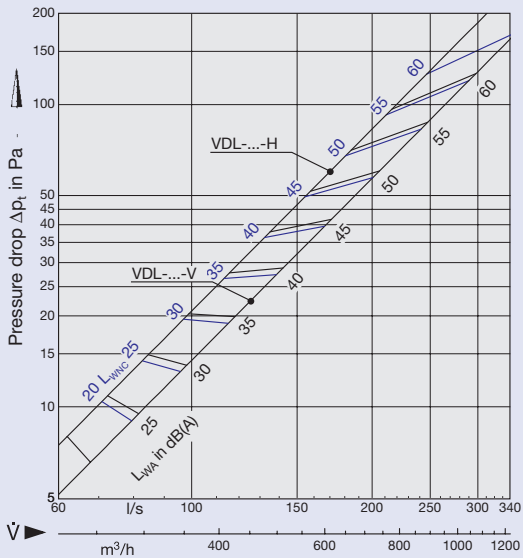

2 Sound power level and pressure drop
Size 400

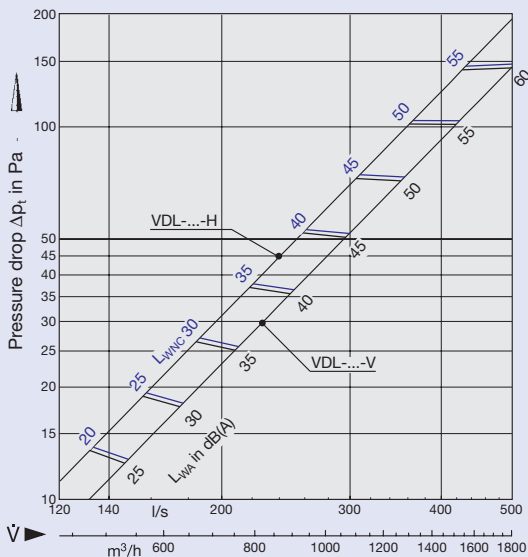

3 Sound power level and pressure drop
Size 630

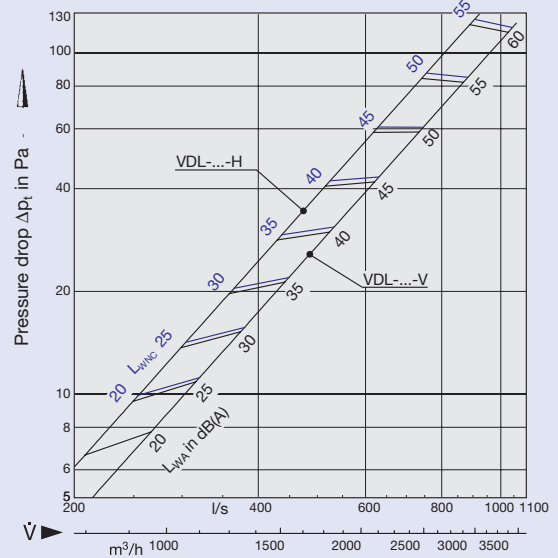

4 Sound power level and pressure drop
Size 800

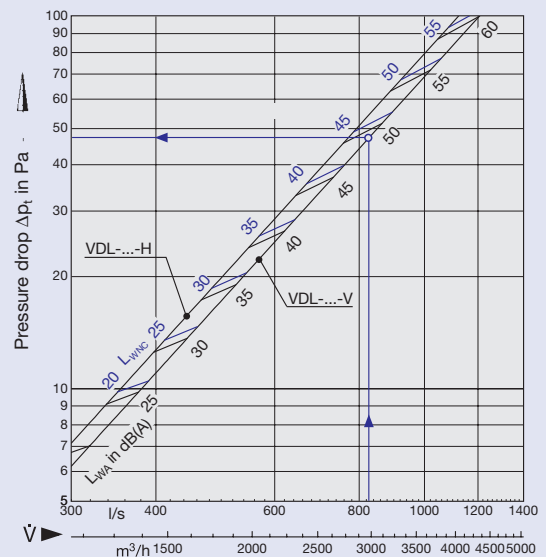

Acoustic Data · Pressure Drop (fixed types)

5 Sound power level and pressure drop
Size 315

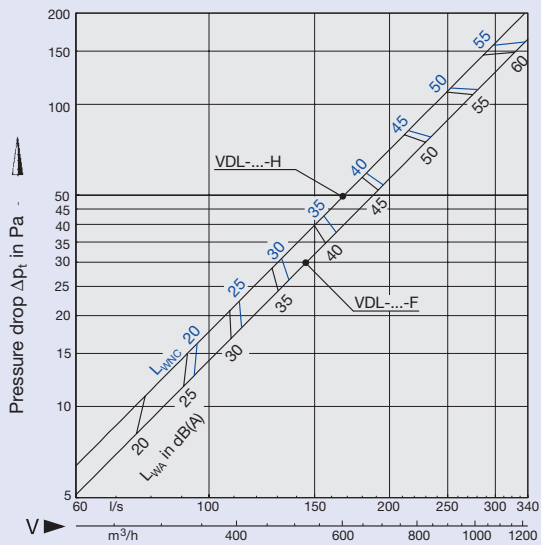

7 Sound power level and pressure drop
Size 630

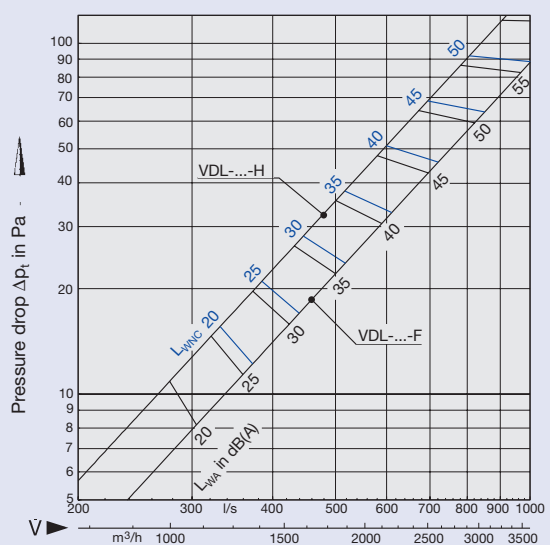

6 Sound power level and pressure drop
Size 400

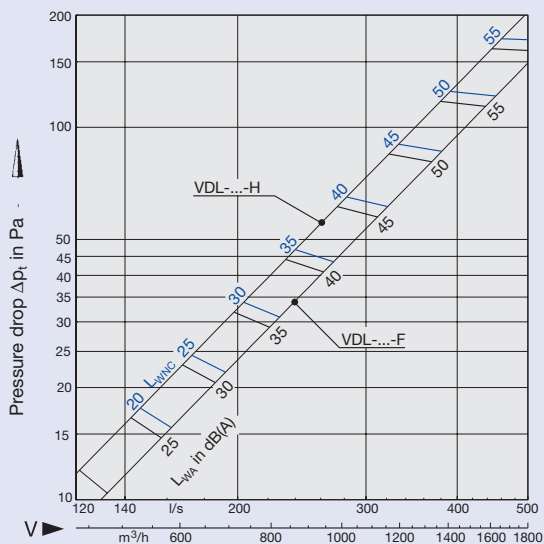

8 Sound power level and pressure drop
Size 800

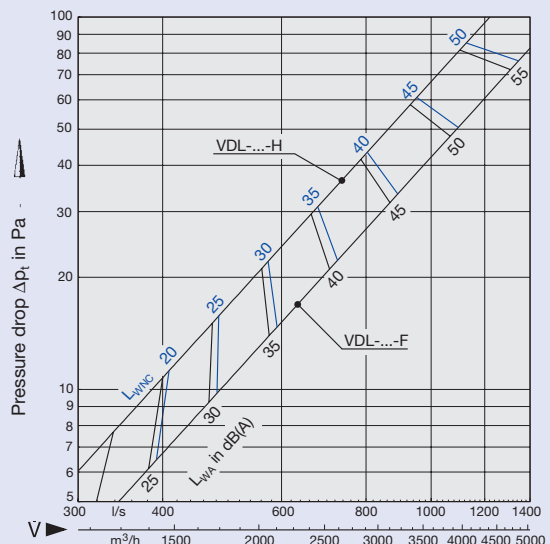

Aerodynamic Data for Heating

9 Max. penetration depth discharge angle 45°

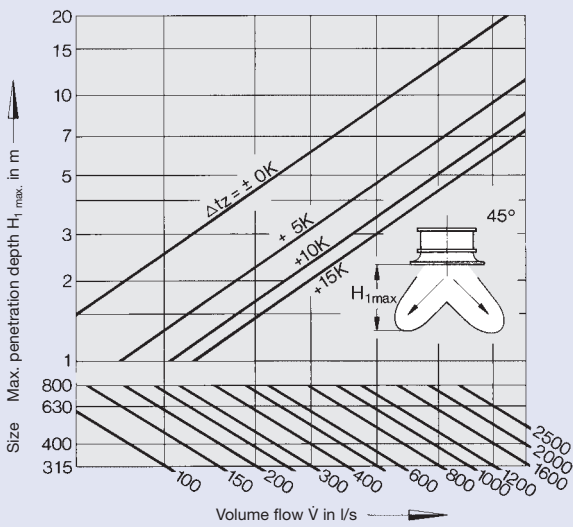

11 Max. penetration depth discharge angle 75°

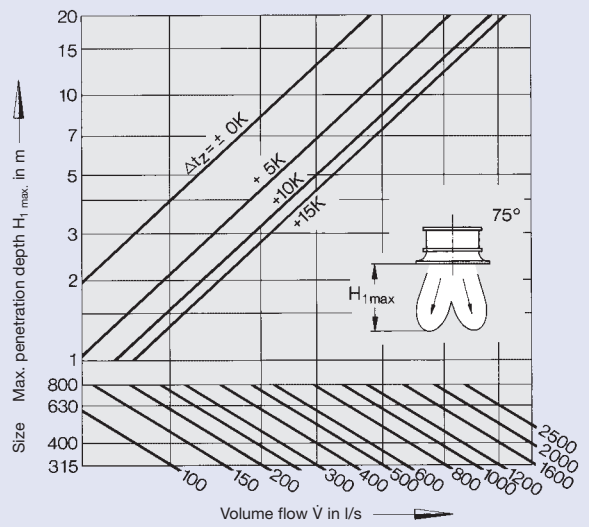

10 Max. penetration depth discharge angle 60°

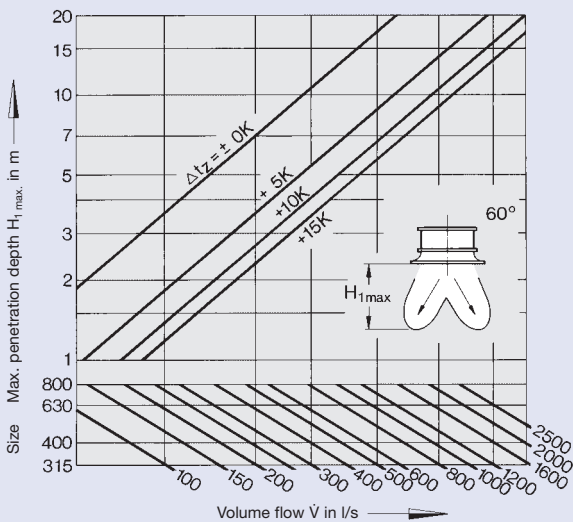

12 Max. penetration depth discharge vertical

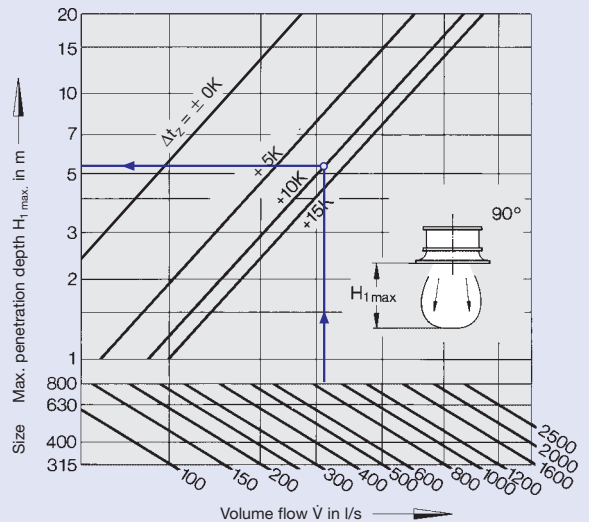

$$\dot{V} [\text{m}^3/\text{h}] = \dot{V} [\text{l/s}] \times 3.6$$

Aerodynamic Data for Cooling

The diagrams are applicable to cooling mode, horizontal discharge diffuser in free space – no ceiling.
Supply air temperature difference: isothermal to -10 K

Correction:
For flush mounting in continuous ceiling, the values for \bar{v}_{H1} must be multiplied by 1.4.

13 Determination of spacing between diffuser centres A
B $\geq 5.00\text{ m}$ Size 315

$H_1 = 2\ 3\ 4 \geq 5\text{ m}$

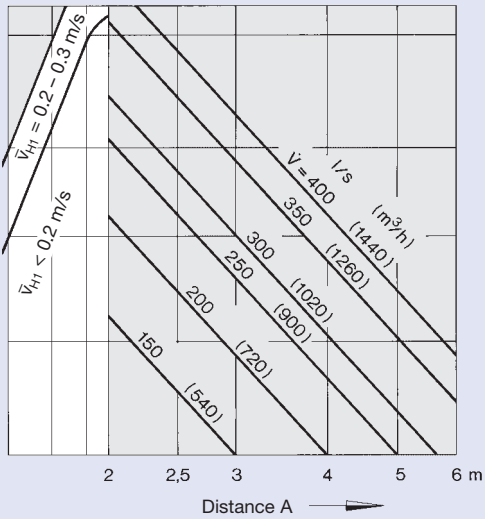

15 Determination of spacing between diffuser centres A
B $\geq 5.00\text{ m}$ Size 630

$H_1 = 2\ 3\ 4 \geq 5\text{ m}$

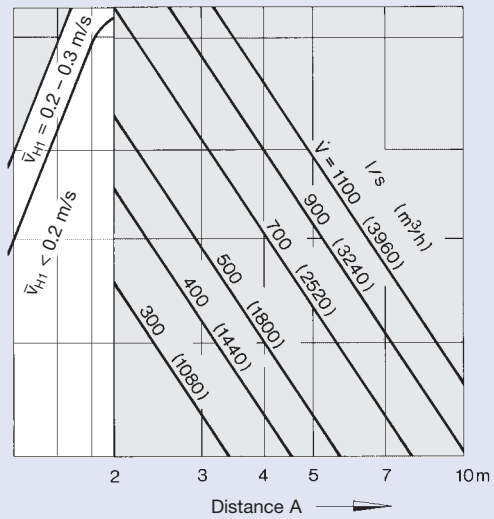

14 Determination of spacing between diffuser centres A
B $\geq 5.00\text{ m}$ Size 400

$H_1 = 2\ 3\ 4 \geq 5\text{ m}$

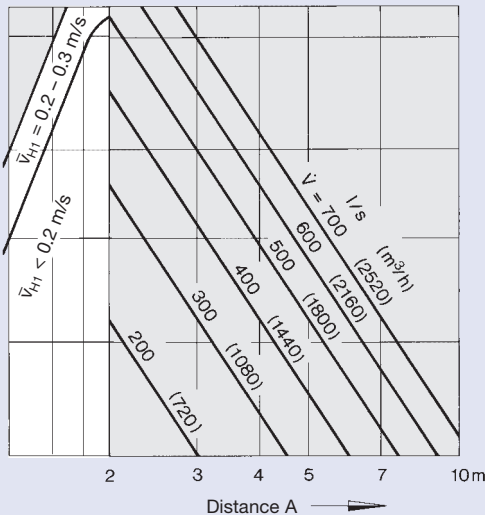

16 Determination of spacing between diffuser centres A
B $\geq 5.00\text{ m}$ Size 800

$H_1 = 2\ 3\ 4 \geq 5\text{ m}$

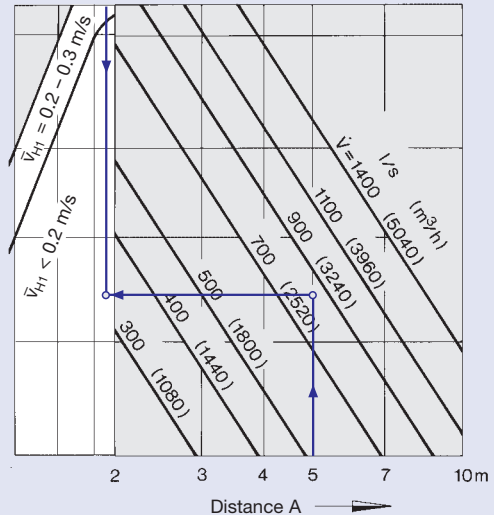

Aerodynamic Data for Cooling

The diagrams are applicable to cooling mode, horizontal discharge diffuser in free space – no ceiling.
Supply air temperature difference: isothermal to -10 K

Correction:

For flush mounting in continuous ceiling, the values for \bar{v}_L and $\Delta t_L/\Delta t_z$ must be multiplied by 1.4.

17 Air velocity at the wall and temperature quotient
Size 315

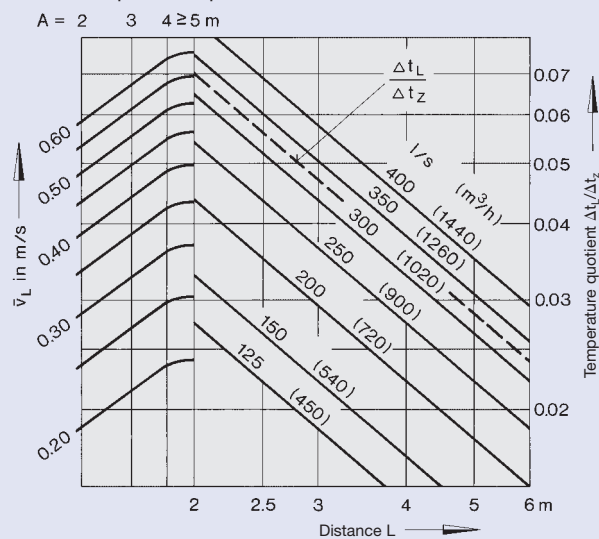

19 Air velocity at the wall and temperature quotient
Size 630

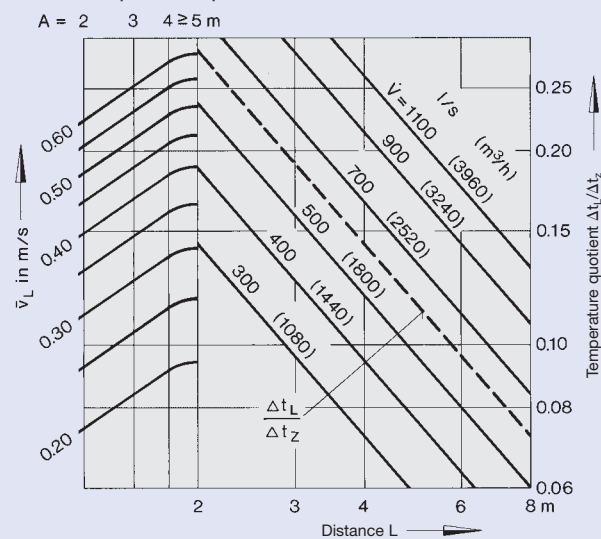

18 Air velocity at the wall and temperature quotient
Size 400

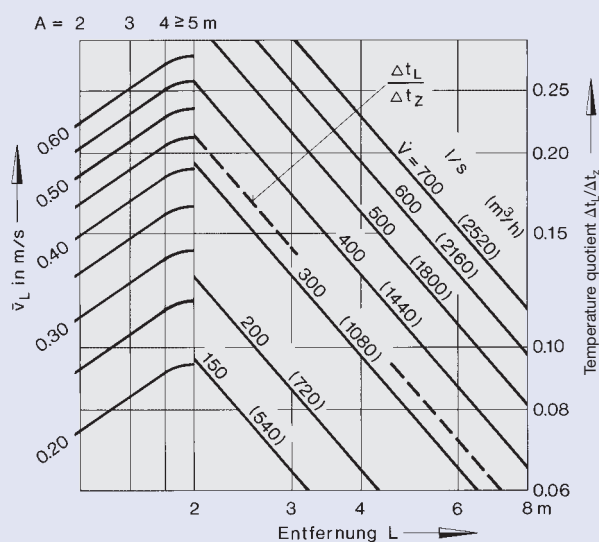

20 Air velocity at the wall and temperature quotient
Size 800

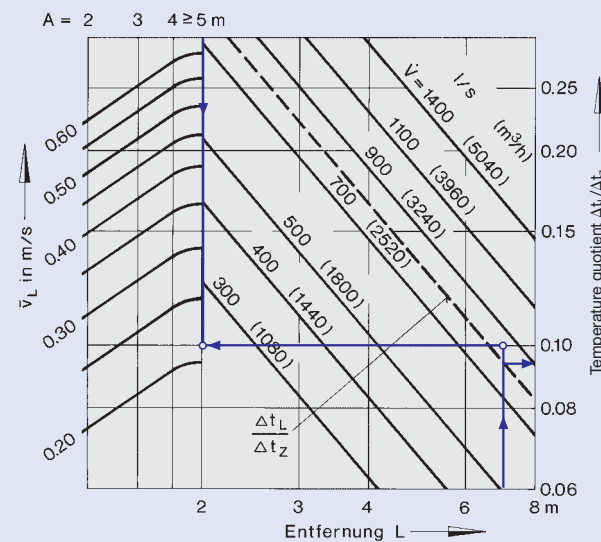

Order Details

Available constructions

Order code	Type / brief description	Size			
		315	400	630	800
VDL-A-F-X VDL-B-F-...-X	diffuser face only, fixed air control blades				
VDL-A-F-M VDL-B-F-...-M	diffuser face only, manually adjustable blades				
VDL-A-V-...-N-M VDL-B-V-...-N-...-M	diffuser face with casing, top entry (additional opposed action swirl blades), diffuser face not removable, manually adjustable				
VDL-A-V-...-D-E1...E3 VDL-B-V-...-D-...-E1...E3	diffuser face with casing, top entry, diffuser face removable, adjustable by actuator				
VDL-A-H-...-N-X VDL-B-H-...-N-...-X	diffuser face with plenum box and side entry spigot, diffuser face not removable, fixed blades				
VDL-A-H-...-D-X VDL-B-H-...-D-...-X	diffuser face with plenum box and side entry spigot, diffuser face removable, fixed blades				
VDL-A-H-...-N-M VDL-B-H-...-N-...-M	diffuser face with plenum box and side entry spigot, diffuser face not removable, manually adjustable				
VDL-A-H-...-D-M VDL-B-H-...-D-...-M	diffuser face with plenum box and side entry spigot, diffuser face removable, manually adjustable				
VDL-A-H-...-D-...-E1...E3 VDL-B-H-...-D-...-E1...E3	diffuser face with plenum box and side entry spigot, diffuser face removable, adjustable by actuator				

Order Code

codes do not need to be completed for standard products

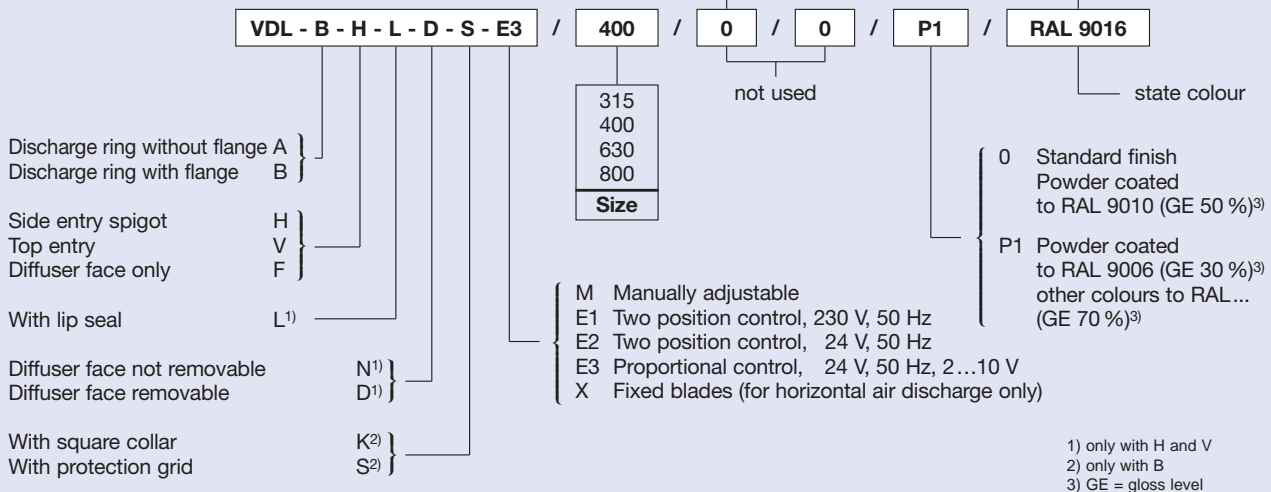

Specification Text

Circular swirl diffuser with adjustable blades complete with outer ring incorporating a discharge nozzle, suitable for horizontal, angled or vertical air discharge controlled by blade position. Suitable for mounting heights of ≥ 3.80 m and variations in supply temperature differentials between -10 K and $+15$ K. Comprising diffuser face with rotating blades adjustable either manually or with electric actuators. Type VDL-...-X with fixed blades for horizontal air discharge only, with side entry plenum box or for direct connection to a circular duct on site.

Order example

Make: TROX
Type: VDL - B - H - L - D - E3 / 400 / P1 / RAL 9016

Materials

The outer ring incorporating a discharge nozzle and the central cover cap are made of aluminium. The blades, casing, spigots and plenum box are made of galvanised sheet steel.

The surface of the diffuser face, collar and protection grid are powder-coated white (RAL 9010, gloss level 50 %), or in another RAL colour if requested (gloss level 70 % or RAL 9006 gloss level 30 %).

Accessories

Square collar (separately) VDL-K / 400 / P1 / 9016
Protection grid (separately) VDL-S / 400 / P1 / 9016