

Swirl Diffusers

- Type XARTO
- For a creative ceiling design

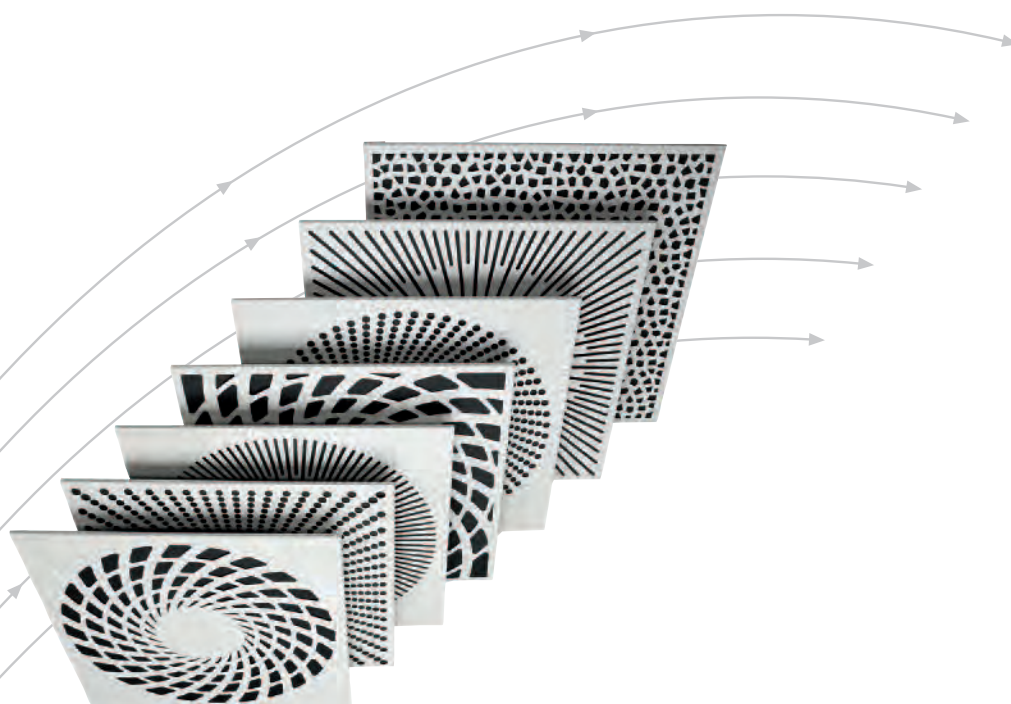

TROX[®] TECHNİK

The art of handling air

Contents · Description

Description	2	Aerodynamic quick selection	
Innovation	3	Square face style	8
Construction · Dimensions	4	Circular face style	9
Installation	5	Face plates	10
Nomenclature	6	Order details	11
Quick selection	7		

XARTO-Q...

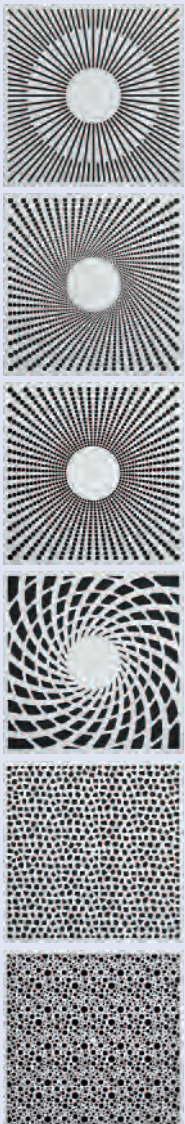

XARTO-R...

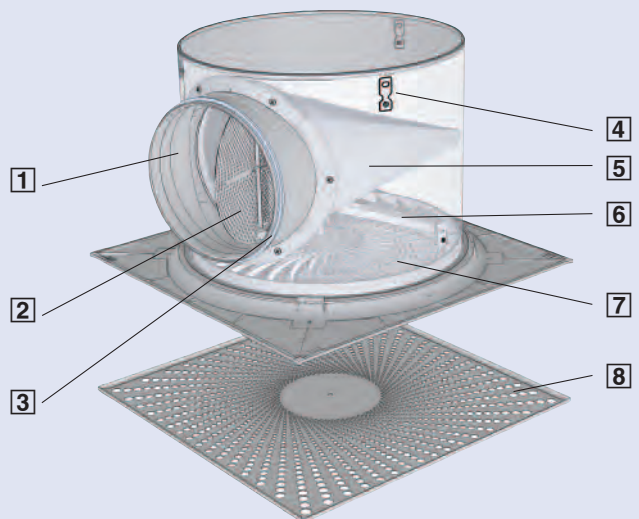
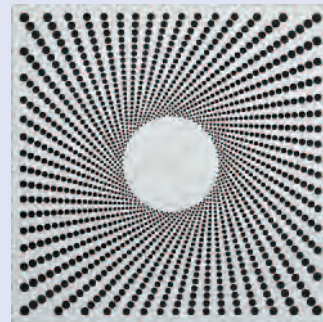
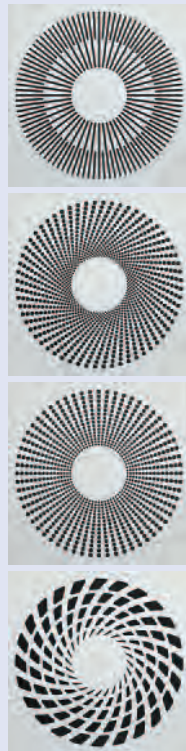

- 1 Spigot
- 2 Damper blade for flow rate balancing
- 3 Double lip seal
- 4 Hanging bracket
- 5 Air distribution element (only for supply air)
- 6 Crossbar for fixing the diffuser face
- 7 Swirl unit (only for supply air)
- 8 Diffuser face plate

- Type XARTO swirl diffusers meet the most demanding requirements in terms of technology, comfort, and design.
- Face plates come in classic, modern and flamboyant styles and can be creatively integrated with all types of ceilings. They form in fact an attractive design element for building owners and architects.

The combination of swirl unit, newly developed air distribution element and innovative plenum box provides high volume flow rates, a low sound power level and low differential pressure.

The air control blades of the swirl unit have three-dimensionally profiled contours to create an efficient swirl. Hence, the air velocity and temperature difference in the occupied zone are very low, and the level of comfort is excellent.

A spigot with double lip seal provides a low leakage connection of the plenum box to the ducting, and a damper blade for flow rate balancing simplifies commissioning.

Advantages

- 10 different face plates offer a multitude of possibilities
- Excellent comfort level as a result of low air velocities and low temperature differences in the occupied zone
- Newly developed air distribution element to ensure a uniform air flow through the supply air diffuser
- Acoustically optimised damper blade for flow rate balancing
- Spigot with double lip seal

Installation examples



Construction · Dimensions

Characteristics

- Square face plates with circular or square diffuser face style
- For supply or extract air
- For installation into suspended ceilings
- Suitable for all types of ceilings
- Side entry spigot
- Damper blade for flow rate balancing, can be set in 15° intervals between 0 and 90°
- Plastic parts made of flame retardant plastic, compliant with German building regulations

Construction features

- Spigot with double lip seal suitable for circular ducts according to EN 1506 or EN 13180.
- Three hanging brackets to suspend the unit using wires, threaded rods, or metal hangers; the hanging system has to be provided by the customer.
- For 600 and 625 mm ceiling grids.



XARTO		Order code
Face style	Application	
Square	Supply air	-Q-Z
	Extract air	-Q-A
Circular	Supply air	-R-Z
	Extract air	-R-A

Materials

- Plenum box and face plate made of galvanised sheet steel, crossbar made of galvanised steel
- Swirl unit, spigot and damper blade made of ABS plastic, UL 94, flame retardant (V0)
- Air distribution element made of synthetic fibre
- Face plate powder-coated, pure white (RAL9010)

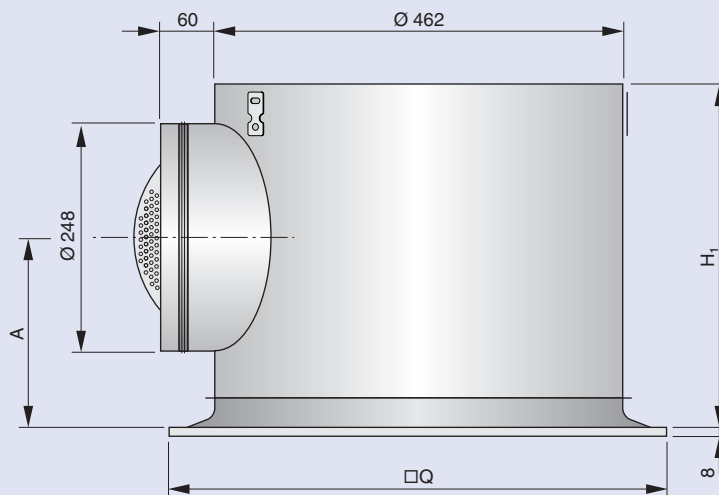
Dimensions



Dimensions in mm		
Face style	H ₁	A
-Q... 	371	220
-R... 	356	205

Dimensions in mm	
Nominal size	□Q
600	598
625	623

Weight in kg		
Face style	-Z	-A
-Q 	9.5	9.0
-R 	9.0	8.5

- Installation of the diffuser, connection to the duct, and provision of connecting and fixing materials have to be undertaken by the customer.

The diffuser must be installed and connected by trained expert personnel only.

All legal regulations for site work must be complied with.

The plenum box has three hanging brackets for fixing it to the ceiling slab. Only fixing systems which have been approved by the building inspectorate should be used.

The spigot forms the connection between the swirl diffuser and the duct. The double lip seal ensures a tight connection. Additional sealing material is not required.

Installation into grid ceilings

The plenum box is suspended from the ceiling slab. The ceiling grid is suspended independent of the diffuser face. The diffuser face can be installed after the false ceiling has been completed.

Installation into plasterboard ceilings

The plenum box is suspended from the ceiling slab. The plasterboard ceiling tile must be independently suspended. The diffuser face can be either flush with the tile or surface mounted (as shown below).

Installation into T-bar ceilings

The plenum box is suspended from the ceiling slab. Once the false ceiling has been completed, the diffuser face can be installed below the T profile.

Flow rate balancing

When several diffusers are connected to just one volume flow controller it may become necessary to balance the volume flow rates. To do so, the face plate can be removed to access the damper blade; the damper blade can then be set in 15° intervals between 0 and 90°.

Installation into suspended ceiling systems

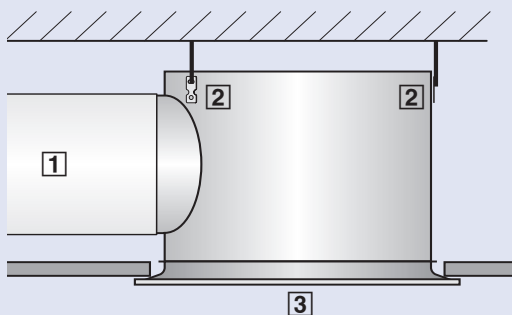

Grid ceiling

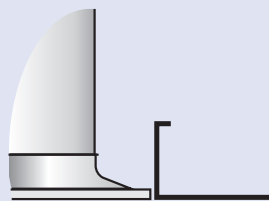

Plasterboard ceiling

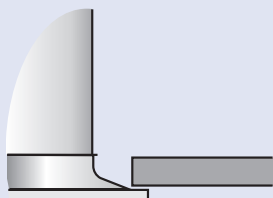

T-bar ceiling

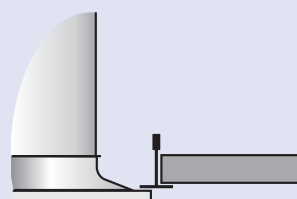

- 1 Duct
- 2 Hanging bracket
- 3 Face plate

Flow rate balancing

Open, 0°

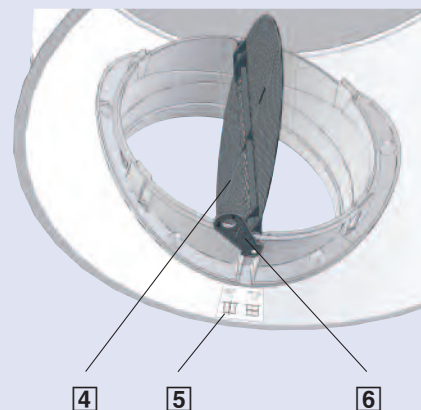

Closed, 90°

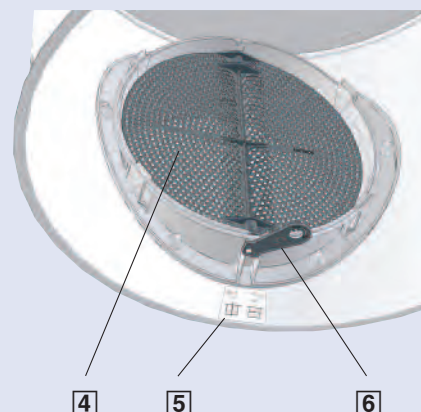

- 4 Damper blade
- 5 Sticker explaining the damper blade position
- 6 Setting lever

Nomenclature

Nomenclature

\dot{V}	in l/s and m ³ /h	: Volume flow rate
\dot{V}_{\min}	in l/s and m ³ /h	: Minimum volume flow rate
Δp_t	in Pa	: Total differential pressure
a	in m	: Spacing between two diffusers
b	in m	: Spacing between two rows of diffusers
x	in m	: Distance from wall
\bar{v}_i	in m/s	: Maximum time average air velocity at the wall
\bar{v}_{h1}	in m/s	: Maximum time average air velocity between two or four diffusers
L_{PA}	in dB(A)	: A-weighted sound pressure level
L_{WA}	in dB(A)	: A-weighted sound power level
L_{WNC}		: NC rating of sound power level ($L_{WNC} \approx L_{WA} - 6$ dB)

The noise levels quoted are the dB (A) rating of the sound power level L_{WA} . A typical room correction of 5 dB/oct. results in a sound pressure level of $L_{PA} \approx L_{WA} - 5$ dB.

All sound power levels are based on 1 pW. All noise levels were determined in a reverberation chamber according to EN ISO 5135.

Technical data based on an air density of 1.2 kg/m³.

Using quick selection for sizing swirl diffusers will rapidly provide optimum results. It ensures compliance with normally acceptable aerodynamic and acoustic limits.

- Air velocity in the occupied zone
- Pressure differential
- Sound power level

The volume flow rates listed in the tables for aerodynamic quick selection are based on cooling mode with a supply air differential of –12 K max.

For a more detailed selection and design of type XARTO swirl diffusers refer to the Easy Product Finder design programme on our website.

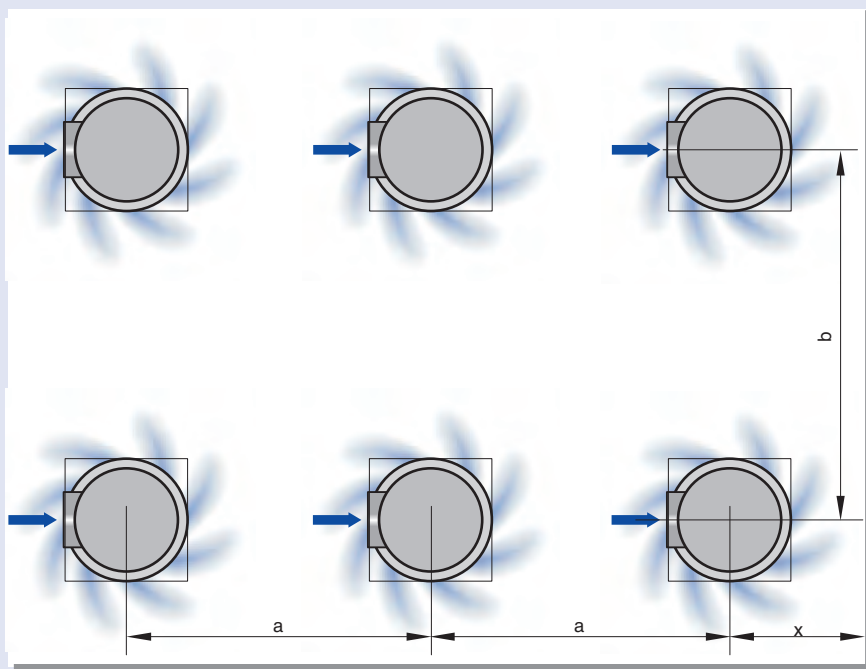
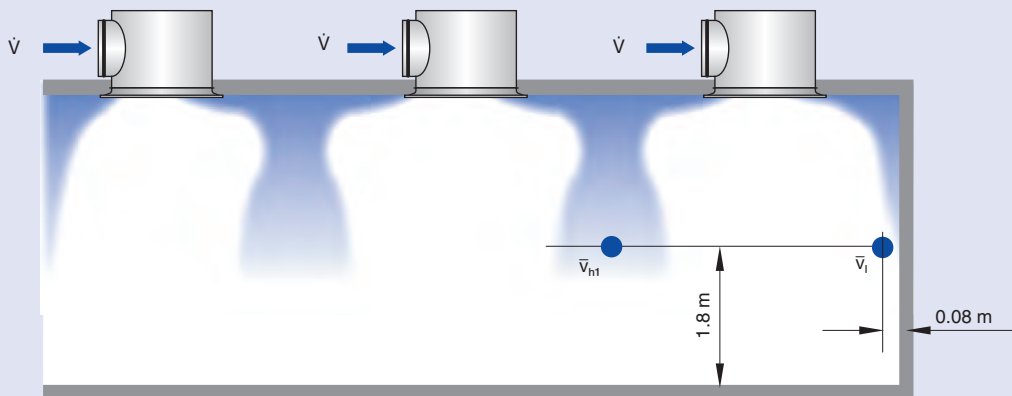

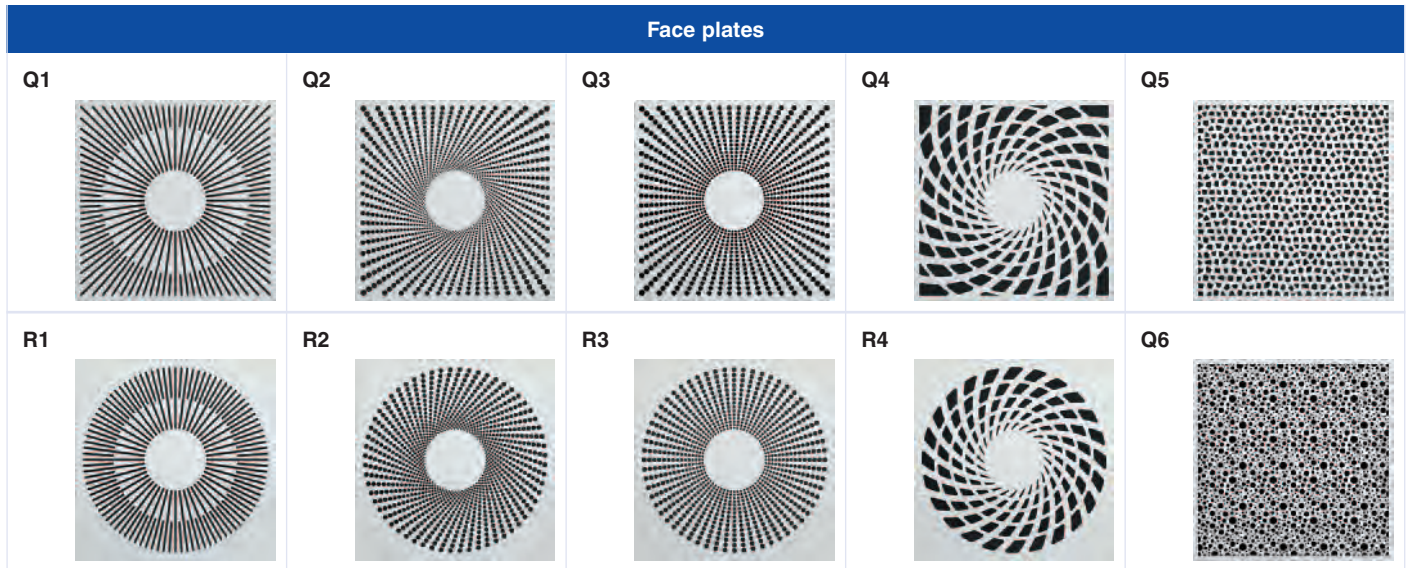

Volume flow rate and total differential pressure for a given sound power level																						
Diffuser type	Damper blade open															Correction values for different damper blade positions						
	\dot{V}_{min}		$L_{WA} = 30 \text{ dB(A)}$			$L_{WA} = 35 \text{ dB(A)}$			$L_{WA} = 40 \text{ dB(A)}$			$L_{WA} = 45 \text{ dB(A)}$			$L_{WA} = 50 \text{ dB(A)}$			45°	90°	45°	90°	
			\dot{V}	Δp_t	\dot{V}	Δp_t	\dot{V}	Δp_t	\dot{V}	Δp_t	\dot{V}	Δp_t	\dot{V}	Δp_t	\dot{V}	Δp_t	$\Delta p_t \times$	$L_{WA} +$				
	l/s	m³/h	l/s	m³/h	Pa	l/s	m³/h	Pa	l/s	m³/h	Pa	l/s	m³/h	Pa	l/s	m³/h	Pa			dB	dB	
Supply air																						
Q1	<input type="checkbox"/>	90	325	145	520	24	170	610	32	195	700	44	230	830	60	270	970	83	1.6	2.9	1	14
Q2	<input type="checkbox"/>			140	505	23	165	595	32	195	700	44	225	810	59	265	955	81	1.6	2.8	1	13
Q3	<input type="checkbox"/>			145	520	23	170	610	31	200	720	42	230	830	58	270	970	79	1.6	2.9	1	14
Q4	<input type="checkbox"/>			135	485	23	160	575	31	185	665	42	220	790	58	255	920	80	1.5	2.5	0	12
Q5	<input type="checkbox"/>			145	520	23	170	610	31	200	720	42	230	830	57	270	970	78	1.6	2.9	1	14
Q6	<input type="checkbox"/>			145	520	24	170	610	32	200	720	44	235	845	59	275	990	81	1.6	3.0	1	14
R1	<input type="checkbox"/>			125	450	18	150	540	25	175	630	35	205	740	49	250	900	69	1.5	2.7	0	10
R2	<input type="checkbox"/>			130	470	19	155	560	27	180	650	37	215	775	52	255	920	72	1.5	2.7	0	11
R3	<input type="checkbox"/>			130	470	19	150	540	26	180	650	36	210	755	51	250	900	71	1.5	2.6	0	10
R4	<input type="checkbox"/>			120	430	18	140	505	25	165	595	35	195	700	49	230	830	68	1.4	2.3	0	8
Extract air																						
Q1	<input type="checkbox"/>			165	595	13	190	685	18	225	810	25	260	935	34	305	1100	47	2.0	5.0	6	16
Q2	<input type="checkbox"/>			160	575	13	185	665	18	215	775	25	255	920	33	295	1060	45				
Q3	<input type="checkbox"/>			165	595	12	190	685	16	220	790	22	255	920	30	300	1080	41				
Q4	<input type="checkbox"/>			155	560	13	180	650	18	210	755	24	245	880	33	285	1025	45				
Q5	<input type="checkbox"/>			165	595	13	190	685	18	225	810	24	260	935	33	305	1100	45				
Q6	<input type="checkbox"/>			160	575	13	190	685	18	225	810	24	260	935	34	310	1115	46				
R1	<input type="checkbox"/>			160	575	13	185	665	17	220	790	24	255	920	32	300	1080	44				
R2	<input type="checkbox"/>			160	575	13	185	665	17	215	775	24	250	900	32	295	1060	44				
R3	<input type="checkbox"/>			160	575	13	185	665	17	215	775	23	250	900	31	290	1045	42				
R4	<input type="checkbox"/>			145	520	14	170	610	19	200	720	26	235	845	35	275	990	49				

Aerodynamic quick selection

Square face style

Example

Given data

Office
 Area: 80 m²
 Height: 2.70 m
 Air velocity in the occupied zone <0.2 m/s
 Three swirl diffusers, design Q2
 Required sound power level per diffuser: 35 dB(A)
 Total volume flow rate: 390 l/s (1405 m³/h)

Aerodynamic quick selection

Minimum distance from wall:
 $x = 1.0$ m
 Distance between two diffusers:
 $a = 1.5$ m (diffusers in a single row)
 The air velocity at the wall remains below 0.35 m/s, and in the occupied zone below 0.2 m/s.

Data for quick selection, page 7

For each swirl diffuser:
 $\dot{V} = 390 \text{ l/s} / 3 = 130 \text{ l/s}$ (470 m³/h)

Quick selection

3 XARTO-Q2-Z / 623
 130 l/s at <30 dB(A)
 $\Delta p_t = <23$ Pa

Maximum volume flow rate for a given distance a or x													
Nominal size	Distance a, x m	Ceiling height 2.7 to 3.0 m						Ceiling height 3.5 to 4.0 m					
		$\bar{v}_l < 0.35$ m/s		$\bar{v}_{ht} < 0.2$ m/s				$\bar{v}_l < 0.5$ m/s		$\bar{v}_{ht} < 0.25$ m/s			
		At the wall (x)		Between two diffusers (a)		Between four diffusers (a) at b = 3.0 m		At the wall (x)		Between two diffusers (a)		Between four diffusers (a) at b = 3.0 m	
		\dot{V}		\dot{V}		\dot{V}		\dot{V}		\dot{V}		\dot{V}	
		l/s	m ³ /h	l/s	m ³ /h	l/s	m ³ /h	l/s	m ³ /h	l/s	m ³ /h	l/s	m ³ /h
Q1 Q3 Q5 Q6	1.0	160	575	115	415	–	–	270	970	240	865	160	575
	1.5	200	720	130	470	–	–			265	950	160	575
	2.0	240	865	120	430	–	–			245	880	160	575
	2.5	270	970	115	415	–	–			230	830	160	575
	3.0	270	970	120	430	–	–			240	865	170	610
	4.0	270	970	240	865	150	540			270	970	270	970
Q2	1.0	155	560	110	395	–	–	265	950	235	845	150	540
	1.5	195	700	130	470	–	–			260	935	150	540
	2.0	235	845	115	415	–	–			240	865	150	540
	2.5	265	955	110	395	–	–			225	810	155	560
	3.0	265	955	115	415	–	–			235	845	160	575
	4.0	265	955	240	865	140	505			265	955	265	950
Q4	1.0	150	540	110	395	–	–	255	920	220	790	145	520
	1.5	190	685	120	430	–	–			250	900	145	520
	2.0	220	790	110	395	–	–			235	845	145	520
	2.5	255	920	105	380	–	–			210	755	150	540
	3.0	255	920	110	395	–	–			220	790	160	575
	4.0	255	920	235	845	135	485			255	920	255	920

Aerodynamic quick selection

Circular face style

Maximum volume flow rate for a given distance a or x													
Nominal size	Distance a, x m	Ceiling height 2.7 to 3.0 m						Ceiling height 3.5 to 4.0 m					
		$\bar{v}_i < 0.35$ m/s		$\bar{v}_{n1} < 0.2$ m/s				$\bar{v}_i < 0.5$ m/s		$\bar{v}_{n1} < 0.25$ m/s			
		At the wall (x)		Between two diffusers (a)		Between four diffusers (a) at b = 3.0 m		At the wall (x)		Between two diffusers (a)		Between four diffusers (a) at b = 3.0 m	
		\dot{V}		\dot{V}		\dot{V}		\dot{V}		\dot{V}		\dot{V}	
		l/s	m ³ /h	l/s	m ³ /h	l/s	m ³ /h	l/s	m ³ /h	l/s	m ³ /h	l/s	m ³ /h
R1 R3	1.0	135	485	100	360	–	–	240	865	205	740	130	470
	1.5	165	595	110	395	–	–	250	900	220	790	130	470
	2.0	200	720	100	360	–	–	250	900	210	755	130	470
	2.5	250	900	95	340	–	–	250	900	195	700	130	470
	3.0	250	900	100	360	–	–	250	900	205	740	140	505
	4.0	250	900	215	775	120	430	250	900	250	900	240	865
R2	1.0	135	485	100	360	–	–	240	865	205	740	130	470
	1.5	165	595	110	395	–	–	255	920	220	790	130	470
	2.0	200	720	100	360	–	–	255	920	210	755	130	470
	2.5	255	920	95	340	–	–	255	920	195	700	130	470
	3.0	255	920	100	360	–	–	255	920	205	740	140	505
	4.0	255	920	215	775	120	430	255	920	255	920	240	865
R4	1.0	120	430	90	325	–	–	220	790	185	665	120	430
	1.5	160	575	100	360	–	–	230	830	200	720	125	450
	2.0	185	665	90	325	–	–	230	830	190	685	125	450
	2.5	230	830	85	305	–	–	230	830	180	650	125	450
	3.0	230	830	90	325	–	–	230	830	185	665	135	485
	4.0	230	830	190	685	110	395	230	830	230	830	220	790

Face plates

Q1

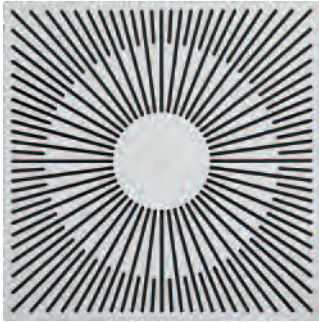

R1

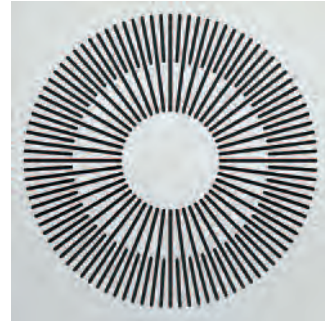

Q2

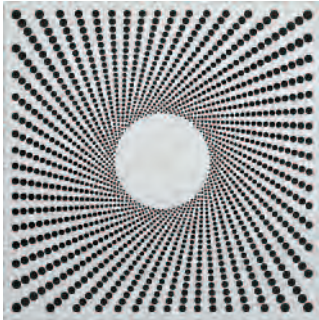

R2

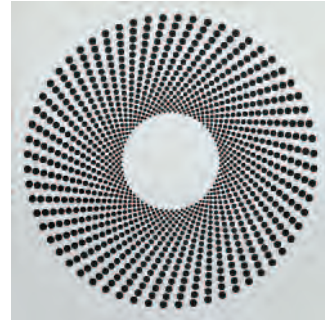

Q3

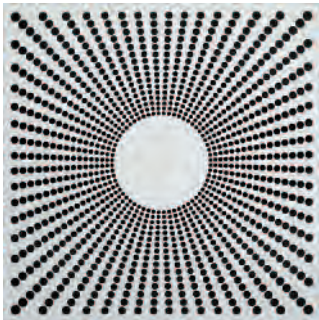

R3

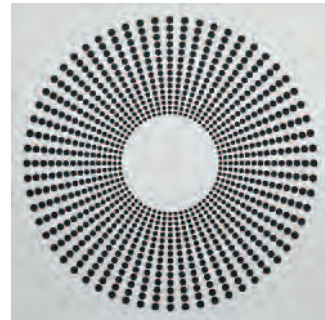

Q4



R4



Q5

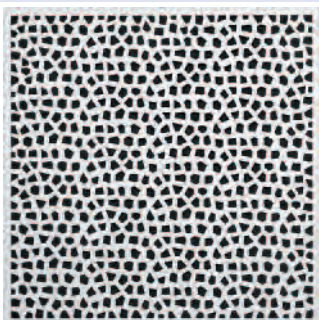

Q6

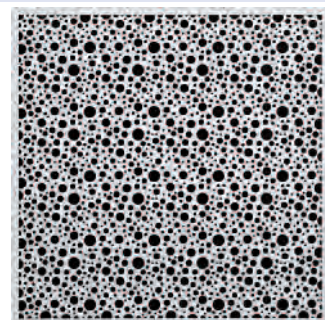

Specification text

Type XARTO swirl diffusers for high levels of comfort and special architectural and design requirements. An excellent aerodynamic and acoustic function is ensured by a swirl unit with aerodynamically optimised control blades as well as by a plenum box with a damper blade for volume flow rate balancing and an air distribution element (supply air). Horizontal air discharge with high induction.

Special characteristics:

- Wide variety of face plates
- Newly developed air distribution element to ensure a uniform air flow through the supply air diffuser
- Acoustically optimised damper blade for flow rate balancing
- Spigot with double lip seal

Consisting of the plenum box with face plate, swirl unit, connecting spigot, and a crossbar for fixing the diffuser face plate. Suitable for conventional grid and plasterboard ceilings.

Side entry spigot with double lip seal, suitable for circular connecting ducts according to EN 1506 or EN 13180, and an acoustically optimised damper blade for flow rate balancing.

Sound power level of air-regenerated noise measured according to EN ISO 5135.

Swirl diffuser options

- XARTO-R...-Z
Supply air diffuser with circular face style
- XARTO-R...-A
Extract air diffuser with circular face style
- XARTO-Q...-Z
Supply air diffuser with square face style
- XARTO-Q...-A
Extract air diffuser with square face style

Materials

Plenum box and face plate made of galvanised sheet steel. Crossbar made of galvanised steel. Swirl element, spigot and damper blade made of ABS plastic, UL 94, flame retardant (V0). Air distribution element made of synthetic fibre.

Face plate powder-coated, pure white (RAL9010)

Order code

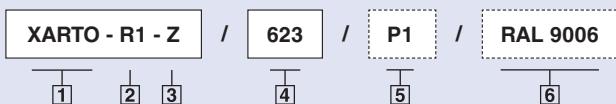

1 Type

2 Diffuser face

Circular face style
R1
R2
R3
R4
Square face style
Q1
Q2
Q3
Q4
Q5
Q6

3 Air type

-Z Supply air
-A Extract air

4 Size of diffuser face plate

598
623

5 Surface¹

Powder-coated, white
(RAL 9010, gloss level 50 %),
no entry required
P1 Powder-coated RAL ...

6 Colour

For P1 only
RAL 9006 white aluminium,
gloss level 30 %
RAL ... other colours,
gloss level 70 %

¹ Colours in RAL CLASSIC collection

Order example

Make: TROX
Type: XARTO-R1-Z / 623

