

# Smoke Detector

- Type RM-O-3-D
- for control of fire and smoke dampers

General Building Approval Z-78.6-125

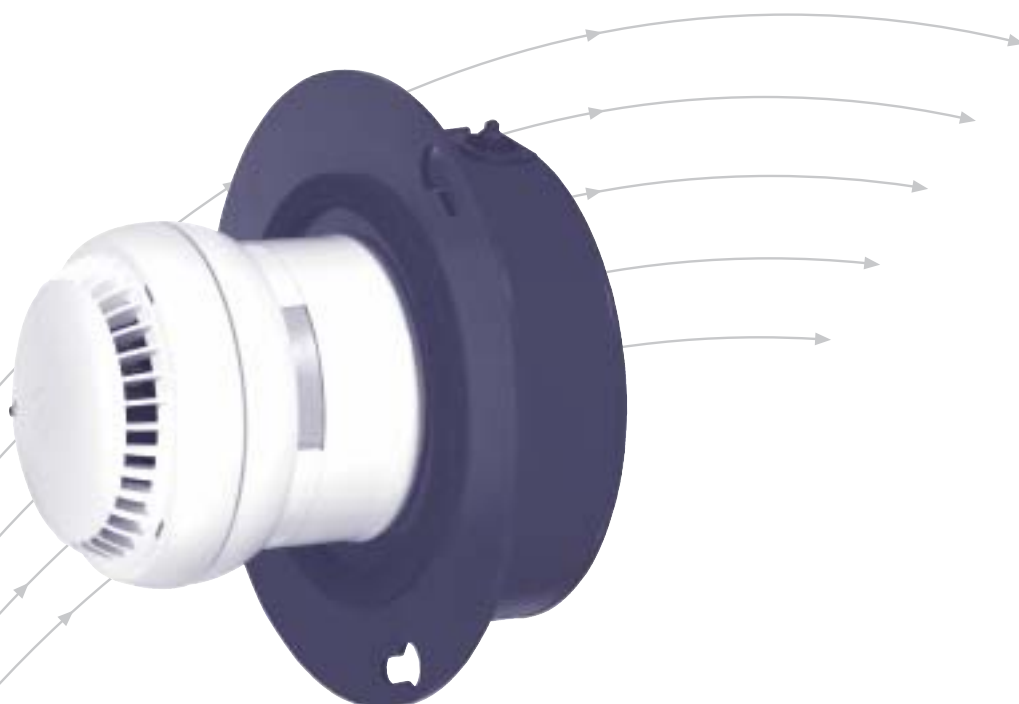

**TROX<sup>®</sup> TECHNIK**

• TROX GmbH  
• Heinrich-Trox-Platz  
• D-47504 Neukirchen-Vluyn

Telephone +49/28 45/2 02-0  
Telefax +49/28 45/2 02-2 65  
e-mail [trox@trox.de](mailto:trox@trox.de)  
[www.troxtechnik.com](http://www.troxtechnik.com)

Contents · Application · Technical Data	2
Installation Instructions	3
Functional Description	4
Circuit Diagrams	5
Maintenance	6
Order Details	7

- ① Smoke detector with mains adapter, smoke sensor and sensor electronics
- ② “Reset / Test” button
- ③ Signal lamp - green - “System monitoring”
- ④ Signal lamp - red - “Alarm condition”
- ⑤ Signal lamp - yellow - “Contamination indicator”



## Application

For control of:

- Fire dampers with electric or electric-pneumatic release mechanisms (power off to operate/close principle)
- Smoke dampers with electric spring return actuators, e. g. TROX type JZ-RS smoke dampers with general building approval Z-78.4-51.

The external quality control stipulated by law is carried out by VdS Schadenverhütung GmbH, Cologne.

### The following should be noted!

- **If a set response threshold for the smoke is exceeded, the smoke detector signals a smoke alarm. The related fire or smoke damper closes.**  
**Fresh air or recirculation fans must be shut down if their continued operation will result in the further spread of smoke.**

## Technical Data

- Supply voltage: 230 V, 50/60 Hz, +10% -15%
- Power consumption: 3 VA
- Protection class: IP 42
- Ambient temperature range: 0 °C to + 60 °C
- Permissible air velocity range: 1 m/s to 20 m/s
- Permissible humidity range: 0 to 90 % relative humidity (Condensation and induction of steam can lead to false alarms)
- Warning limit for increased contamination: > 70 %
- System monitoring: > 90 % contamination; Smoke sensor head missing; Data transmission from smoke sensor defective
- Alarm relay contact (release signal, contamination): 250 V, 2 A, 24 V DC, 100 W
- EMC: Interference protection to EN 61000-6-1 to EN 61000-6-4
- Weight: approx. 0.7 kg

- **Signalling of the contamination must be transmitted to a centre, a highly visible operating or control unit or at a building control system (BMS).**
- **“Regulations on fire protection requirements for ventilation plants” all applicable National Codes must be observed.**
- **The smoke detector may not used to send an alarm to the fire service.**
- **Before commissioning the ventilation plant, the sensor heads must be protected against contamination by building dirt (dirt particles can result in false alarms).**
- **The “General and Special Regulations” of the General Building approval must be observed.**
- **Installation and maintenance instructions can be found in the leaflet enclosed with every delivery.**

## Information for installation

Power supply for the 24 V release mechanisms of fire and smoke dampers is not available from the smoke detector.

# Installation Instructions

- ① Smoke detector with mains adapter, smoke sensor and sensor electronics
- ⑪ Cover plate
- ⑫ Smoke sensor
- ⑬ Cover fixing screws (2 off)
- ⑥ Ventilation duct, by others
- ⑦ Drilling template
- ⑧ Fixing screws (3 off)

## Installation instructions

- The smoke detector must be installed on a vibration free surface, in an area of the duct to be monitored, having a uniform air flow over and into the smoke sensor to ensure the proper operation of the smoke alarm.
- Stick the drilling template item ⑦ on the ventilation duct item ⑥ and drill holes (consider the orientation).
- Using the fixing screws item ⑧, attach the casing to the ventilation duct item ⑥.
- Loosen the cover fixing screws item ⑬ and remove the cover plate item ⑪.
- Connect the fire or smoke damper release mechanism.
- Connect electrical wiring for external functions, e.g. manual remote release (optional).
- Connect to mains supply.
- Refit the cover plate item ⑪ and secure with cover fixing screws item ⑬.

## Dimensions



↑  
Connection point for electrical wiring (by others)

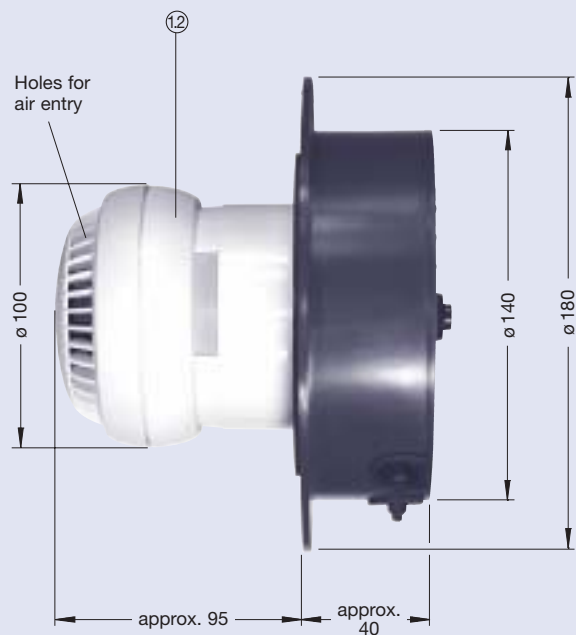

## Arrangement

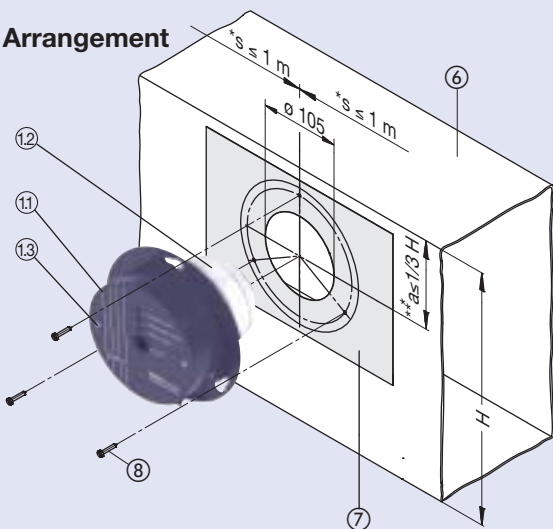

Use drilling template supplied

## Drilling template A

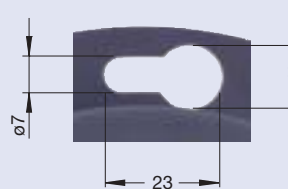

\* s = max. distance to fire or smoke damper  
Deviations, e.g. due to structural conditions, are only allowed, if reliable smoke detection can be guaranteed.

\*\* for horizontally installed ventilation ducts

# Functional Description

Fire or smoke damper		Operational status / Event	Signal	Signal relay		
OPEN	CLOSED			LED lamp - red -	LED lamp - yellow -	LED lamp - green -
		Mains turned on - Functional status -	LED			
			Contact			
		Mains not turned on	LED			
			Contact			
		Mains turned on Electronics defective No smoke sensor - Alarm situation, immediate release signal -	LED			
			Contact			
		Dust / Contamination > 70 % < 90 % 1)	LED			
			Contact			
		Dust / Contamination > 90 % - Alarm situation, immediate release signal -	LED			
			Contact			
		Reset / Test - Inspection -	LED			
			Contact			
		Smoke - Alarm situation, immediate release signal - 2)	LED			
			Contact			

## 1) Contamination indicator

- up to 70 % - Normal range
- > 70 % to 90 % - Warning range
- > 90 % - Alarm range



LED lit



LED flashing



LED off!

- 2) The alarm situation, triggered by smoke (event or maintenance), can only be cancelled by pressing the button after the smoke sensor is again free of smoke.

The entire electrical system must be installed in accordance with VDE (or National equivalent) and the local Energy Supply Company regulations.

Also current National Legal Standards related to the "Regulations on fire protection requirements for ventilation plants" must be complied with.

Figure 1 Circuit diagram RM-O-3-D  
(Fire or smoke damper in **CLOSED** position)

Figure 2 Installation with separate power supply for the release mechanism A on the system fire or smoke damper

**Figure 1**

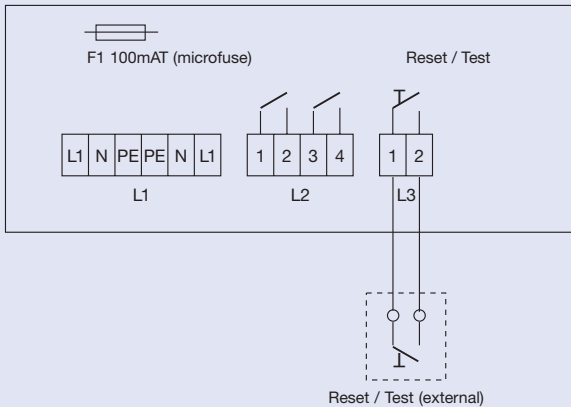

**Six-point terminal strip (L1)**

- Mains connection 230 V, 50/60 Hz, + 10 % – 15 %

**Four-point terminal strip (L2)**

- Contamination signalling - terminals 1 and 2 (potential-free)
  - Connection release mechanism - terminals 3 and 4 (potential-free)
- Breaking capacity 250 V, 2 A, 24 V DC, 100 W

**Two-point terminal strip (L3)**

- Reset / Test external - terminals 1 and 2

**A** The number of release mechanisms that can be connected depends on the total power consumption of the systems.

**Figure 2**

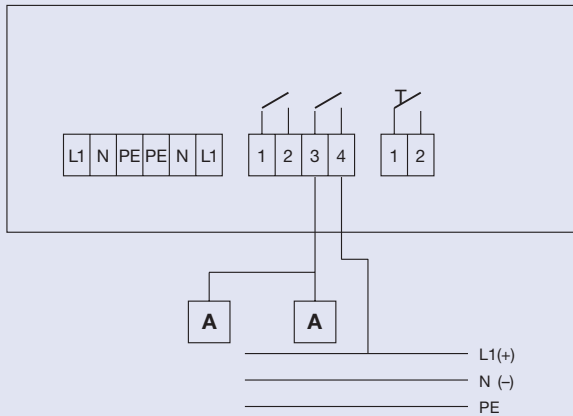

# Maintenance

## General

- The operator must comply with the basic maintenance requirements in accordance with DIN 31051 (Principles of maintenance) in conjunction with DIN EN 13306 (Maintenance concepts).
- Maintenance activities may only be carried out by qualified companies / specialist staff.
- The results of all maintenance activities must be documented. These documents should be held by the operator. Documentation should also include the General Building Approval.
- Inspection and maintenance must be carried out annually.

## Inspection (at commissioning phase and after any modifications)

To be checked:

- Application and installation situation
- Electrical connections and no loose wires
- Electrical interaction of signal transmitter, indicators and control devices on the fire or smoke damper
- Flow rates (guarantee of smoke detection)

## Maintenance (annually during the inspection)

- With contamination above 70 % (yellow signal lamp flashing) clean the smoke sensor by blowing out with clean compressed air (oil and moisture free). If unsuccessful, the smoke sensor must be replaced.
- Remove impurities from the dirt protection screens on the air entry holes (smoke sensor and flow monitor unit).

- ① Smoke detector with mains adapter, smoke sensor and sensor electronics
- ①① Cover plate
- ①② Smoke sensor
- ② "Reset / Test" button
- ③ Signal lamp - green - "System monitoring"
- ④ Signal lamp - red - "Alarm condition"
- ⑤ Signal lamp - yellow - "Contamination indicator"

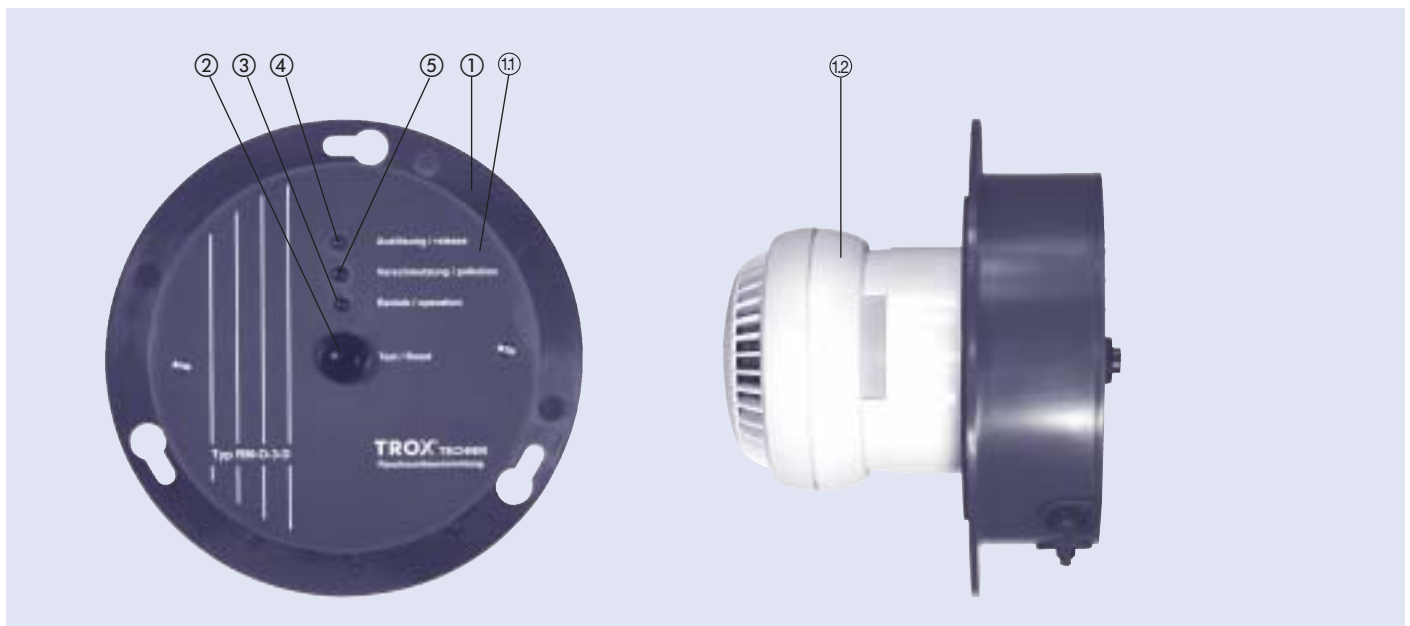

## Functional checks

(at commissioning and repeated every year)

### Without smoke

- Press the "Reset / Test" button on the smoke detector or in the control centre (optional). The circuit to the release mechanism located on the fire or smoke damper is broken; the fire or smoke damper closes. After the button is released, fire or smoke dampers with spring return actuators automatically return to the OPEN position.

### Warning!

Fire dampers with solenoid release mechanisms can only be opened again on site by hand.

### With smoke

- Check response of the smoke sensor by blowing a test aerosol in an opening in the ventilation duct, which is in direct proximity to the smoke detector (on site check).

- When the permitted concentration limit is exceeded, the fire or smoke dampers in the system will close. To re-open – once the smoke sensor is free of smoke – the "Reset / Test" button must be pressed.

### Warning!

All operating, warning and alarm functions are described on page 4.

## Repair

- All defects found during inspection or maintenance must be remedied immediately.
- Defective or contaminated smoke sensor must only be replaced with original TROX components.
- The smoke detector can only be repaired by the manufacturer.

## Order code

RM - O - 3 - D

## Specification text

Smoke detector (smoke sensing using optical light scatter principle) to prevent transfer of smoke via the ventilation ducting in air conditioning systems. Suitable for control and release of fire and smoke dampers with General Building Approval equipped with electric or electro-pneumatic release mechanisms and working on the principle of power off to close.

### Essential features

- Granted General Building Approval Z-78.6-125 by the German Institute for Structural Engineering, Berlin
- Can be used for air velocities of 1 m/s to 20 m/s
- Independent of air flow direction
- With integral mains adapter (supply voltage 230 V, 50/60 Hz)
- With potential-free signal and alarm relays
- With integrated signal lamps
- With contamination level indicator and "tracking" of sensitivity threshold (long service life)
- Can be used regardless of product or manufacturer
- Annual maintenance

## Order example

Manufacturer: TROX

Type: RM - O - 3 - D

Quantity: 5